

Lightning and EMP protection

Edition 2012



We bring protection to perfection



Your partner for system solutions

HUBER+SUHNER is a leading international producer and supplier of electrical and optical interconnectivity components and systems. Core capabilities in radio frequency, fiber optic and low frequency technology are united under a single roof.

The success of the company's high-grade standard products and customised applications is based on its cutting edge-know how in radio frequency and microwave technology, supported by advanced simulation processes.

Lightning and EMP protection solutions

Four decades of experience in developing and manufacturing coaxial lightning EMP and NEMP protectors are the foundation of the current HUBER+SUHNER RF-protection portfolio.

Our products are designed to meet the stringent requirements of the RF/microwave, telecommunications and wireless industry and cover civil, security and defence applications. An extensive high-voltage impulse laboratory is established to verify our designs in accordance with the valid international lightning, surge and NEMP standards. Important inventions are covered by world - wide patents.

Leading by experience

RF know how

- More than half a century of experience in developing and manufacturing coaxial components including more than 20 years intensive investigation of passive intermodulation (PIM) effects.

Protection know how

- Expertise in lightning / NEMP protection since 1976
- With numerous designs HUBER+SUHNER is the benchmark in the lightning protector industry
- Expertise in lightning / NEMP related international standardization

Large portfolio

- Large product portfolio for communications, defence and industrial applications

Production know how

- Manufacturing in most modern facilities with equipment and processes that meet the highest standards.

Testing

- Operating an extensive pulse test laboratory
- Access to state of the art RF test equipment
- Runs laboratory capable of performing all major environmental tests

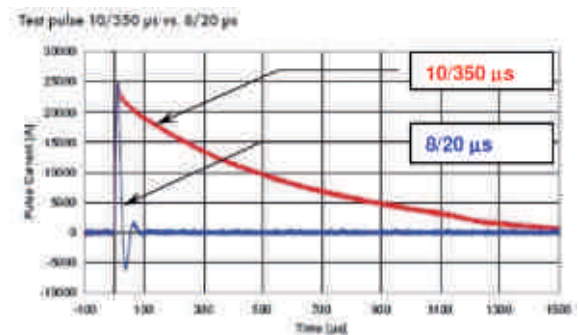

Leading by technology

Careful selection of the most suitable protection technology is crucial for effective protection with long term reliability. HUBER+SUHNER offer a large variety of protection technologies/solutions for radio frequency, microwave, data line and DC/AC applications. Important inventions are covered by world-wide patents.

Milestones:

- HUBER+SUHNER made the unsurpassed, most efficient and reliable quarter-wave shorting stub principle to a worldwide industry standard in RF protection.
- HUBER+SUHNER invented the hybrid GDT protector with decoupled gas discharge tube to support the telecommunications industry with multicarrier, high RF power and low passive intermodulation applications.
- HUBER+SUHNER provided the first broadband quarter-wave shorting stub protector for broadband solutions as well as wideband GDT protectors up to 6 GHz.
- HUBER+SUHNER increased the reliability for GDT based protectors with the invention of the self-extinguishing GDT technology known as SEMPER™.
- HUBER+SUHNER holds groundbreaking patents in the field of coaxial lightning protection such as:

Decoupled EMP protector (hybrid GDT protector)
Automatically quenching surge arrester (SEMPER™)

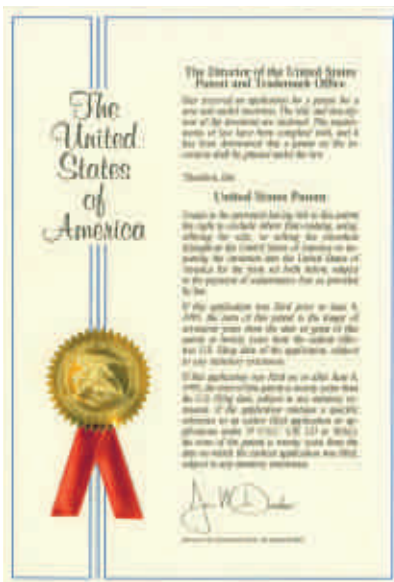
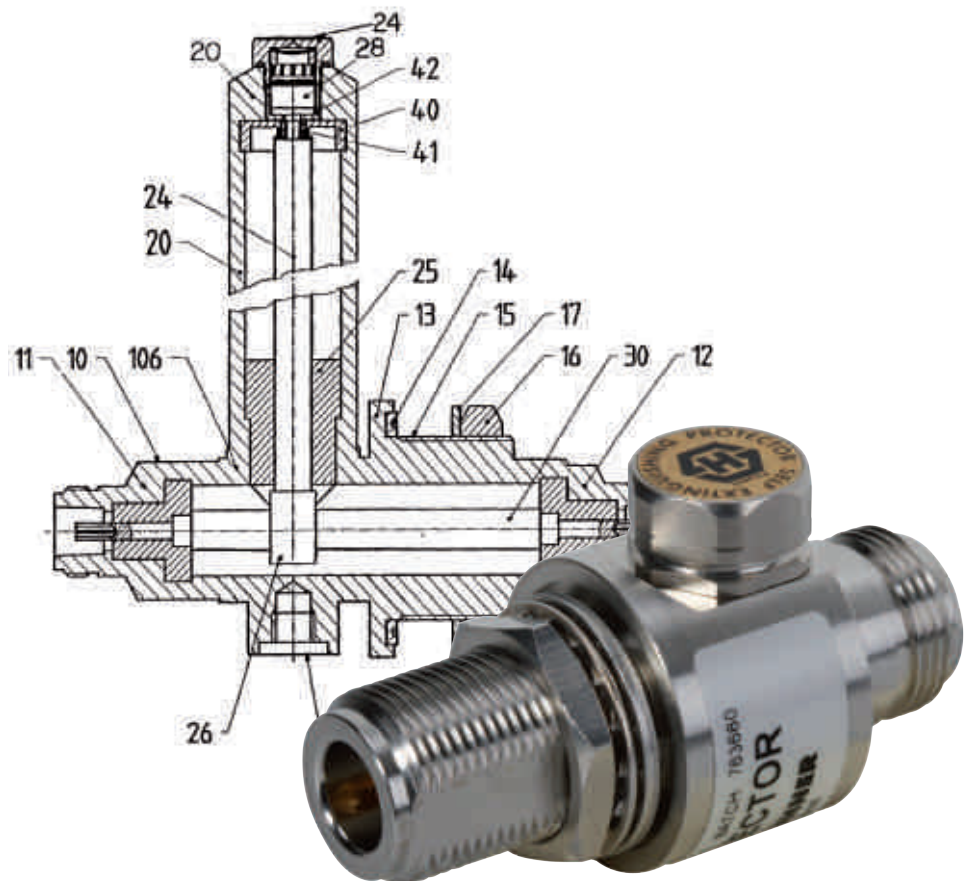

Leading by performance

Highlights

- Products which meet the specifications and perform long term stability
- Products which are designed to cope with highest lightning parameters
- Products which reduce the lightning / EMP pulse to minimal residual voltage and energy (Fig 1, Fig 2)
- Products which RF performance remains unchanged before and after the lightning strike (Fig 3, Fig 4)
- PIM optimized gas discharge tube protectors
- The world's first self-extinguishing GDT protector (SEMPER™)
- GDT hybrids performing with 25 kW peak instantaneous power
- Broadband components
- Material selections which allow to meet the hardest environmental requirements
- Support of varied mounting and grounding options

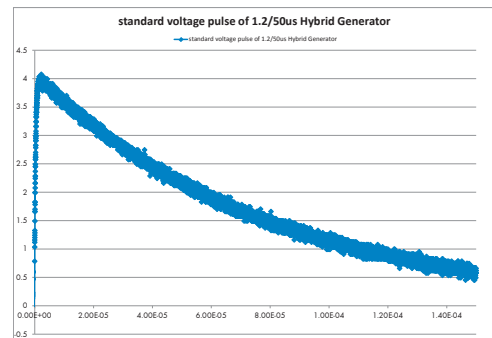

Fig 1: Input pulse 4 kV (1.2/50 μ s)

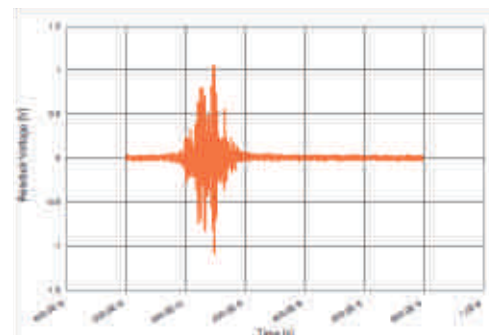

Fig 2: Residual pulse of LC filter protector

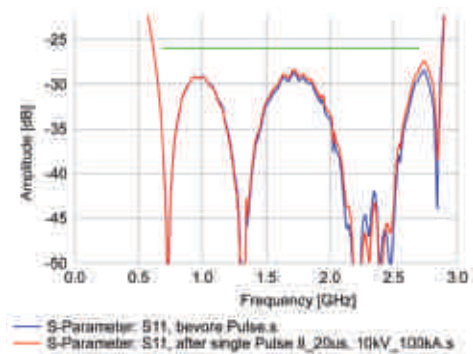

Fig 3: RL before and after 100 kA (8/20 μ s) pulse

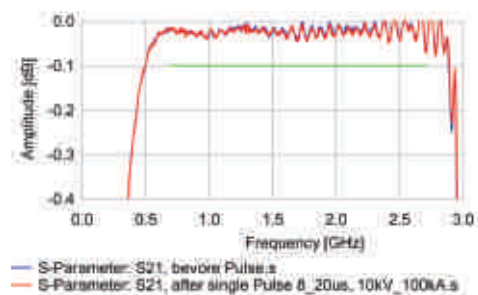

Fig 4: IL before and after 100 kA (8/20 μ s) pulse

Leading by product range



Gas discharge tube protectors with exchangeable GDTs

«Series 3401/3402» (standard versions)

For applications with RF and DC components on the antenna line the standard GDT lightning / EMP protectors feature DC continuity and large bandwidth. Most HUBER+SUHNER GDT protector designs are performing excellent in the NEMP application as well. For specific applications internally DC-blocked GDT protectors are also available.



Self-extinguishing GDT protectors (SEMPER™)

The HUBER+SUHNER SEMPER design guarantees safe extinguishing of the GDT under high RF power or with additional DC components on the antenna line.

By retrofitting standard GDTs with the SEMPER GDT existing installations can be upgraded. The SEMPER technology is a real improvement to the standard gas tube technology and increases reliability and lifetime of GDT protectors.



True broadband GDT protectors

«Series 3406»

SlimLine GDT protectors feature high return loss in the frequency band between DC to 6 GHz. This design is best suited for Point to Point and WLAN equipment.



Hybrid / low PIM / high power GDT protectors

«Series 3409»

This patented technology features low passive intermodulation at extremely high continuous and peak instantaneous power (up to 25 kW PIP).



Bias-T / DC injectors with integrated lightning protector

«Series 3401/3402»

Bias-T's, used to «feed-in» or «pick-off» DC voltage into or from antenna feeder cables, provide the operating voltage for active electronics installed on the mast (mast head amplifiers, etc.)

Leading by product range



Hybrid GDT fine protectors

«Series 3403»

For very sensitive DC powered receivers as used in GPS installations, the hybrid GDT fine protectors with integrated transient voltage suppressor diodes guarantee lowest residual pulse energy.

HUBER+SUHNER fine protectors do feature DC continuity.



Quarter-wave shorting stub protectors

«Series 3400»

HUBER+SUHNER quarter-wave shorting stub protectors perform best lightning parameters with excellent RF specifications within limited bandwidth. A ratio of 4:1 between lowest and highest frequency of the frequency band is achievable by still meeting high return loss. For specific applications internally DC-blocked quarter-wave shorting stub protectors are also available.



Filter protectors

«Series 3407»

LC or LCL band pass filter technologies allow to increase the bandwidth to ratios larger than 4:1 in a compact mechanical design, hence they are an alternative to quarter-wave shorting stub protectors. LC or LCL filter protectors are internally DC-blocked.



Data line protectors

«Series 3414» (twisted pair, ethernet)

Our CAT 5 and CAT6 (Gigabit)data line protectors are «Power Over Ethernet» compatible and available as IP68 rated robust components for outdoor applications (i.e. backhaul microwave links) or in IP20 specified housings for indoor installations (i.e. data processing centers).

Leading by product range



DC/AC protectors

«Series 9079»

Overvoltage protectors for applications up to 100 V DC, or 75 V AC based on varistor technology are available as single components.



Customized DC/AC overvoltage protection systems

«Series 3420»

We also offer customized DC/AC overvoltage protection systems packed in ruggedized IP68 rated outdoor housings.



Grounding kits

«Series 9076»

High quality grounding kits, which do not need extra weatherproofing measures for long term installations in harsh environment.

Capable to divert 100 kA (8/20 μ s) and 25 kA (10/350 μ s) lightning current.



High voltage DC and DC/DC blocks

«Series 9077»

Coaxial DC blocking components (DC blocks) with blocking voltage between 1 kV ; 4 kV and 15 kV are offered in a frequency range between 160 MHz and 3 GHz. High voltage DC blocks are used in railway applications but are also helpful in EMP protection applications to filter out the low frequency spectrum of the electromagnetic pulse.

Leading to your perfect solution



Mobile communications

A truly complete product line of coaxial lightning and surge protectors covering all major protection technologies, frequency bands, installation options and interfaces in combination with Bias-T's, data line protectors and AC/DC protectors meet all market requirements.

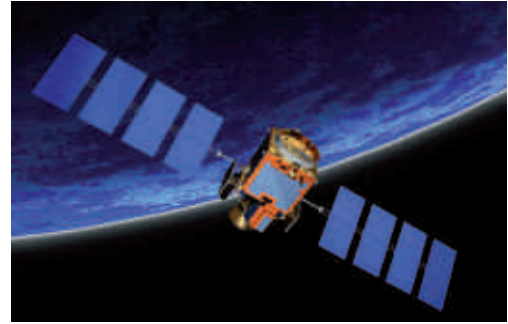

GPS

Hybrid fine protectors based on GDT technology for DC powered GPS receiver applications and quarter-wave shorting stub protectors for GPS systems without remote powering are accessible.



Navigation

A set of protectors specifically designed to meet the top quality standard for airport navigation equipment (ILS, VOR, DME, OM or airport surveillance radars) is established and used by operators and in OEM's air navigation systems.

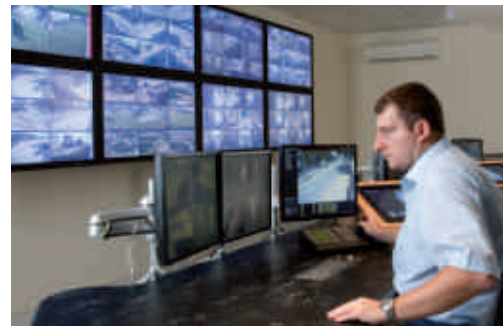

Security

In mission critical applications availability is crucial and no compromise in quality is allowed. The HUBER+SUHNER protector portfolio offers a range of products for government and public safety applications between 70 MHz and 870 MHz.



Broadband wireless

A variety of coaxial GDT protectors including fine protectors and broadband quarter-wave shorting stub protectors are available for the protection of traditional RF and microwave broadband wireless applications (DC to 6 GHz).

For equipment with twisted pair (data line) connections we offer our CAT 5 and Gigabit CAT6 data line protectors.



Defence

Four decades of experience in developing and manufacturing coaxial NEMP and LEMP protectors have made HUBER+SUHNER a first address when it comes to employments in the defence market. HUBER+SUHNER offers protection components for land based, airborne and naval tactical communications, navigation and electronic warfare applications. Many of our protectors are referenced by the NATO Maintenance and Supply Agency (NAMSA).

Visit our website

www.wireless-infrastructure.com

HUBER+SUHNER is certified according to
ISO 9001, ISO 14001, ISO/TS 16949 and IRIS.

WAIVER

It is exclusively in written agreements that we provide our customers with warrants and representations as to the technical specifications and/or the fitness for any particular purpose. The facts and figures contained herein are carefully compiled to the best of our knowledge, but they are intended for general informational purposes only.

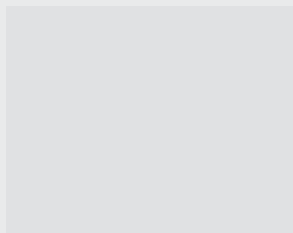

HUBER+SUHNER AG
Radio Frequency Division
Degersheimerstrasse 14
9100 Herisau
Switzerland
Tel. +41 71 353 4111
Fax +41 71 353 4444
info@hubersuhner.com

23029400_RevA/01.2012



hubersuhner.com